

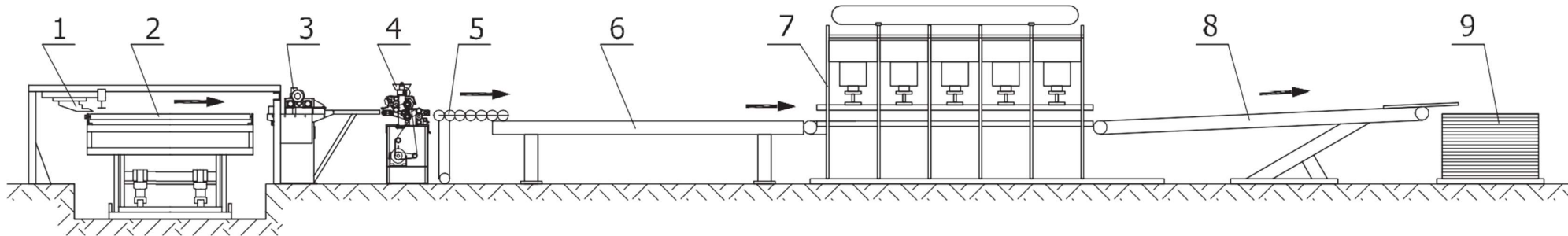

PLANT FOR THE PRODUCTION OF PANEL PLATES

44.23/10.4.1



Purpose:

- for blockboard panels production, made of wood.

1. Middle part producing machine
2. Plate pusher
3. Cleaning device
4. Glue spreader
5. Angle conveyor
6. Input conveyor
7. Hydraulic press
8. Output conveyor
9. Stacking table

Main technical data:

Heating plates size	2600 x 4600 [mm]	On request
Size of finished panels	1400 x 2550 [mm]	
Specific pressing pressure	max 120 [N/cm ²]	
...	...	